

# Fastener Type

## RAPTOR® SH/04

### 16 Gauge Composite Staple

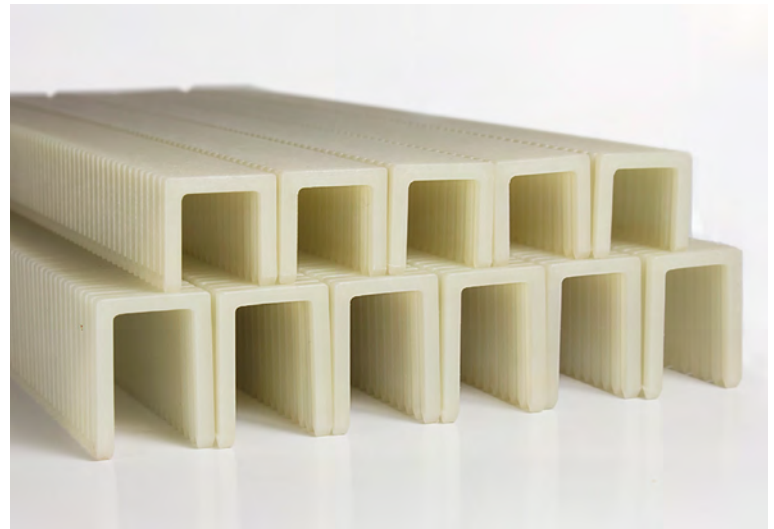
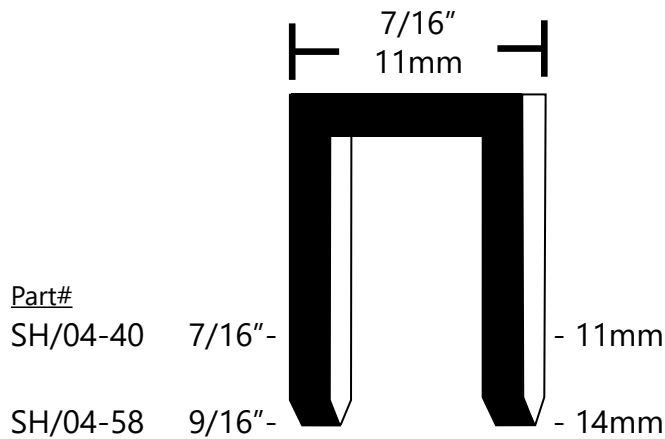

Packaging: 5040 staples per box • 20 boxes per case

#### BENEFITS

- ✓ **Sawable, Sandable & Planeable**
- ✓ **Never Rusts or Corrodes**
- ✓ **Bonds Like Glue**
- ✓ **Completely Non-Metal**

#### APPLICATIONS

Lumber wrap  
 Lumber tagging  
 Boatbuilding  
 Fiberglass lay up  
 Composites manufacturing  
 Radiant barrier installation  
 Wire installation  
 House wrap  
 Casket lining  
 Casegoods tagging

#### TOOLS

Pneumatic:  
 OMER 83P Series  
 RC-SH/04 Cap Stapler

Manual:  
 RAPTOR® G-3PS  
 Hammer Tacker (<9/16")  
 RAPTOR® CT-H7000P  
 Compression Tacker (<9/16")

#### Material Grades:

**Standard Material:** Provides the best drivability. It is not recommended for high speed steel moulder knives but it is fine for carbide blades. In one particular customer test, Titan V24RW, BB knives were used with our standard RAPTOR® product fastened in a line and the knives showed no signs of damage.

LF Material: Safe for most moulder blades but drivability is somewhat compromised.

NF Material: Safe for all delicate blades but drivability is somewhat compromised.

**Colors:** RAPTOR® fasteners are available in colors such as White, Brown, Redwood, Cedar, Blue, Red and Gray. Please contact us for minimum order requirements and lead times.

